

WATER FLOW CONTROLLERS

FLV400 Series

\$1139

All Models



- ✓ Linear 0 to 5 Vdc Output Signal
- ✓ Liquid Flow Rates as Low as 13 mL/min
- ✓ Superior Long-Term Stability, Accuracy, and Repeatability
- ✓ Removable Sensor
- ✓ Very Low Average Power Demand (Approximately 1.25 W)
- ✓ NIST-Traceable Calibration

The FLV400 Series controller accurately measures and controls liquid flows. The sensors are matched to the servo valve for each of the ranges to be covered—up to 2 L/min in liquids. A linear electrical output signal is provided for recording data. These controllers eliminate the need for continuous monitoring and manual readjustment of water pressures.

The heart of the FLV400 is the flow sensor, which uses a Pelton-type turbine wheel to determine the flow rate. The rotation rate of the turbine wheel is linear over a wide dynamic range. The electro-optical system consists of a diode emitting energy in the infrared spectrum. Light energy is alternately reflected and absorbed from “spokes” deposited on the small turbine wheel. A photo diode detects this reflected light. Thus, as the turbine wheel rotates in response to flow rates, electrical pulses are generated. Processing circuitry produces a DC voltage output proportional to the flow rate. A bidirectional linear stepper motor moves a micro-flow control valve in response to any error between the desired flow rate and the actual flow rate as measured by this flow sensor. In addition, precise flow rate settings may be set and maintained automatically over long periods. The user can also change the flow rate from one setting to another remotely. Flow rate is unidirectional and is marked for proper direction on the serial number nameplate.

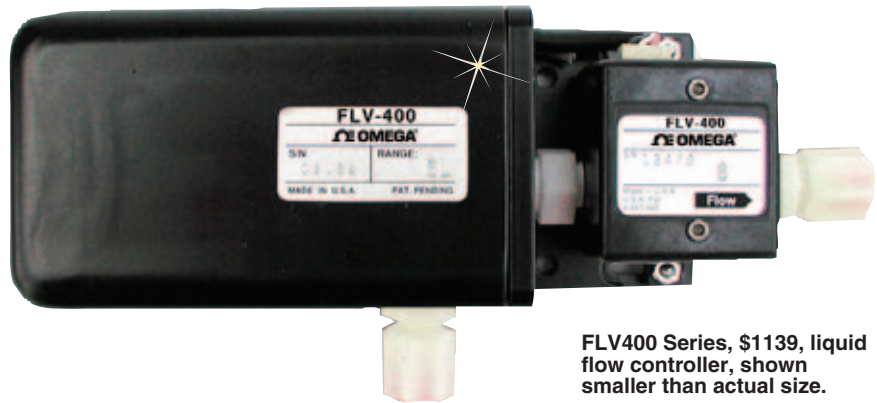

FLV400 Series, \$1139, liquid flow controller, shown smaller than actual size.

SPECIFICATIONS

Accuracy: ±3% FS
Linearity: ±3% FS
Repeatability: ±1% FS
Attitude Sensitivity: Not sensitive
20 to 95% of Full Scale Response: 10 s
Temperature Range: 10 to 40°C (50 to 104°F)
Storage Temperature: 0 to 50°C (32 to 122°F)
Max Pressure: 100 psig
Max Viscosity: 10 centistokes
Input: 0 to 5 Vdc
Output Signal: 0 to 5 Vdc (into a 2500 Ω minimum load impedance; short circuit protected)

Command Signal: 0 to 5 Vdc (from a voltage source with a maximum impedance of 5000 Ω)
Input Power: 12 Vdc at 0.17 A (2 W); DC voltage can range from 11 to 15 Vdc
Note: 0.6 m (2') long leads are supplied; #26 gauge signal, command and power (see color code with cable)
Weight: 0.57 kg (1.25 lb)
Wetted Materials: 40% glass-filled polyphenylene sulfide, glass window, stainless steel pivots, valve stems, bearing supports and sapphire bearings; white epoxy paint deposited on turbine wheels to simulate “spokes” and PTFE TFE or acetal (Polyoxymethylene)
Tube Fitting: 1/8" tube fittings for flow rates through 100 mL/min; 1/4" tube fittings for higher flow rates; flow controllers are normally shipped with FKM O-rings and Polyoxymethylene (acetal) fittings; customer may specify PVDF fittings (available at additional cost upon request).

WARNING:

Do not exceed flow rate specified. Running sensor continuously at flow rates higher than specified values can damage sapphire bearings and stainless steel support shafts.

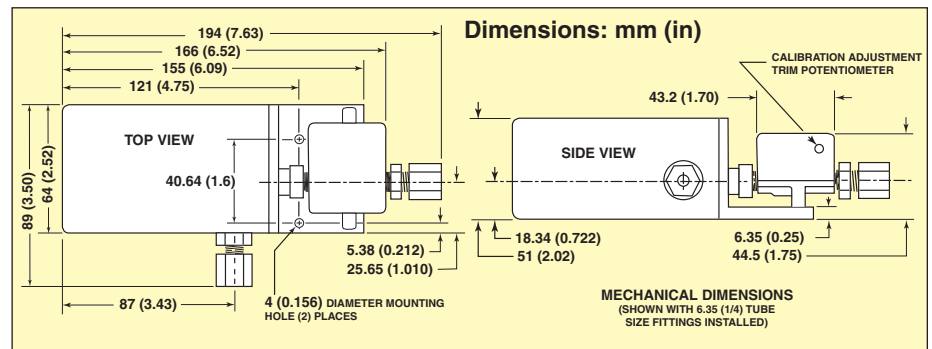

CUSTOM MODELS BUILT TO ORDER!

To Order (Specify Model Number)

Model No.	Price	Water Flow Range
FLV401-(*)	\$1139	13 to 100 mL/min
FLV402-(*)	1139	20 to 200 mL/min
FLV403-(*)	1139	50 to 500 mL/min
FLV404-(*)	1139	60 to 1000 mL/min

*Specify inlet/outlet pressure. Comes with complete operator's manual, NIST calibration and 0.9 m (3') cable with 9-pin D connector and mating connector with stripped leads cable.
Ordering Example: FLV403-Water-50/0 psig, 50 to 500 mL/min controller for water, \$1139.

omega.co.uk[®]

Your One-Stop Source for Process Measurement and Control!

Freephone 0800 488 488 | International +44(0) 161 777 6622 | Fax +44(0) 161 777 6622 | Sales@omega.co.uk

www.omega.co.uk



UNITED STATES

www.omega.com

1-800-TC-OMEGA
Stamford, CT.

CANADA

www.omega.ca

Laval(Quebec)
1-800-TC-OMEGA

GERMANY

www.omega.de

Deckenfronn, Germany
0800-8266342

UNITED KINGDOM

www.omega.co.uk

Manchester, England
0800-488-488
+44-(0)161-777-6611

FRANCE

www.omega.fr

0800-466-342

BENELUX

www.omega.nl

0800-099-33-44



More than 100,000 Products Available!

• Temperature

Calibrators, Connectors, General Test and Measurement Instruments, Handheld Instruments for Temperature Measurement, Ice Point References, Indicating Labels, Crayons, Cements and Lacquers, Infrared Temperature Measurement Instruments, Recorders, Relative Humidity Measurement Instruments, PT100 Probes, PT100 Elements, Temperature & Process Meters, Timers and Counters, Temperature and Process Controllers and Power Switching Devices, Thermistor Elements, Probes and Assemblies, Thermocouples, Thermowells and Head and Well Assemblies, Transmitters, Thermocouple Wire, RTD Probes

• Flow and Level

Air Velocity Indicators, Doppler Flowmeters, Level Measurement, Magnetic Flowmeters, Mass Flowmeters, Pitot Tubes, Pumps, Rotameters, Turbine and Paddle Wheel Flowmeters, Ultrasonic Flowmeters, Valves, Variable Area Flowmeters, Vortex Shedding Flowmeters

• pH and Conductivity

Conductivity Instrumentation, Dissolved Oxygen Instrumentation, Environmental Instrumentation, pH Electrodes and Instruments, Water and Soil Analysis Instrumentation

• Data Acquisition

Communication Products and Converters, Data Acquisition and Analysis Software, Data Loggers Plug-in Cards, Signal Conditioners, USB, RS232, RS485, Ethernet and Parallel Port Data Acquisition Systems, Wireless Transmitters and Receivers

• Pressure, Strain and Force

Displacement Transducers, Dynamic Measurement Force Sensors, Instrumentation for Pressure and Strain Measurements, Load Cells, Pressure Gauges, Pressure Reference Section, Pressure Switches, Pressure Transducers, Proximity Transducers, Regulators, Pressure Transmitters, Strain Gauges, Torque Transducers, Valves

• Heaters

Band Heaters, Cartridge Heaters, Circulation Heaters, Comfort Heaters, Controllers, Meters and Switching Devices, Flexible Heaters, General Test and Measurement Instruments, Heater Hook-up Wire, Heating Cable Systems, Immersion Heaters, Process Air and Duct, Heaters, Radiant Heaters, Strip Heaters, Tubular Heaters