

# OPTICAL LIQUID-LEVEL SENSOR

LV170 Series

**\$144**



LV171, \$144, shown larger than actual size.



- ✔ **Compact—Fits Interstitial Spaces**
- ✔ **Unaffected by Vapors, Even at High Concentrations**
- ✔ **Easily Removed, Cleaned, and Reinstalled**
- ✔ **No Moving Parts**

The LV170 optical liquid sensor accurately detects the presence of liquid in fiberglass double-wall tanks, containment sumps, and double-wall pipes. Built-in electronic switching ensures dependability throughout its long service life. This reusable sensor easily fits small, interstitial spaces and senses liquid hydrocarbons or water. The unit is unaffected by hydrocarbon vapors,

thereby greatly reducing the risk of false alarms. The LV170 sensor is easy to remove, clean, and reinstall after an alarm condition is triggered, or for maintenance.

The LV170 electro-optical sensor contains an infrared LED and a light receiver. Continuous light from the LED is directed into a prism that forms the tip of the sensor.

If no liquid is present, light from the LED is reflected within the prism to the receiver. When rising liquid immerses the prism, the light is refracted out into the liquid, leaving little or no light to reach the receiver. Sensing this change, the receiver actuates electronic switching within the unit to operate an external alarm or control circuit.

**Note:** The LV170 sensor is a non-voltage-producing device and does not contain energy storing components. However, because primary use is in hazardous locations, an appropriate intrinsically safe interface device is required for its use.

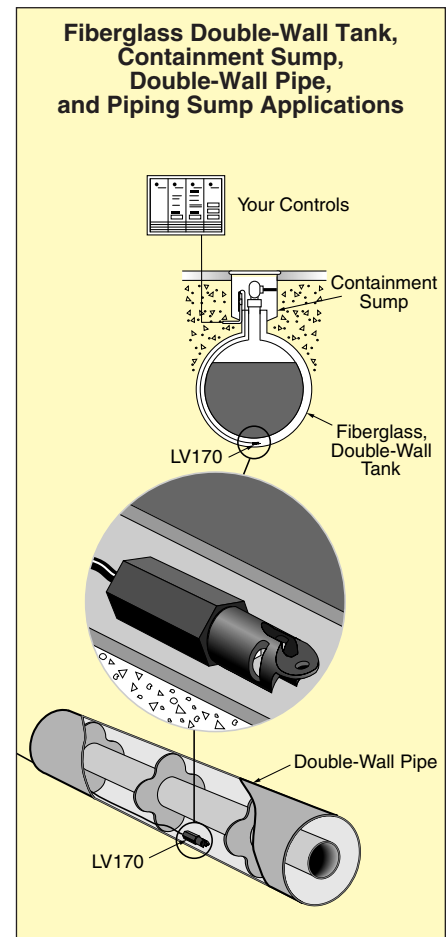
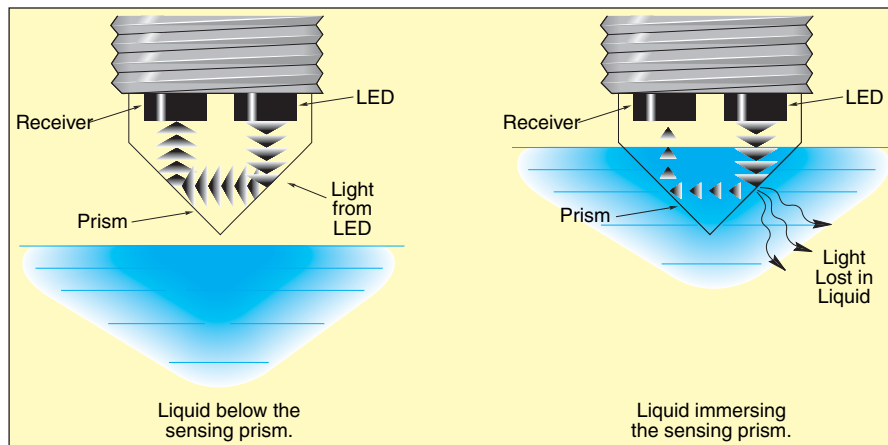

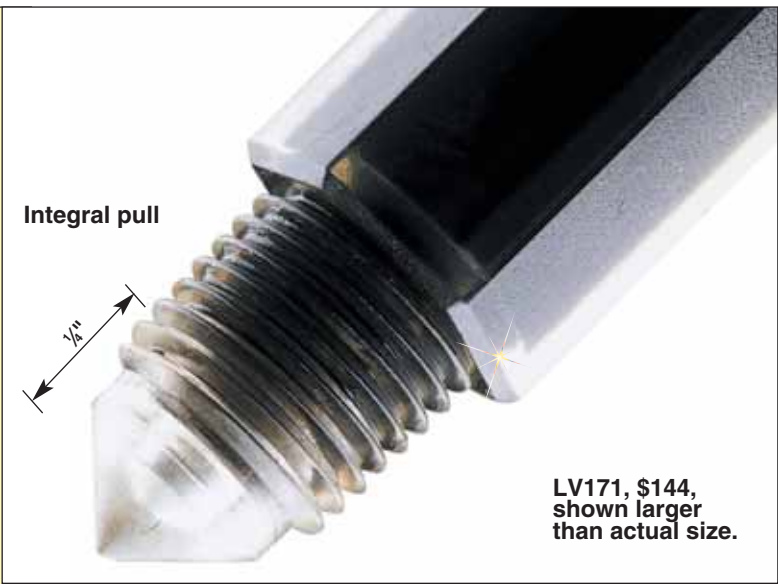
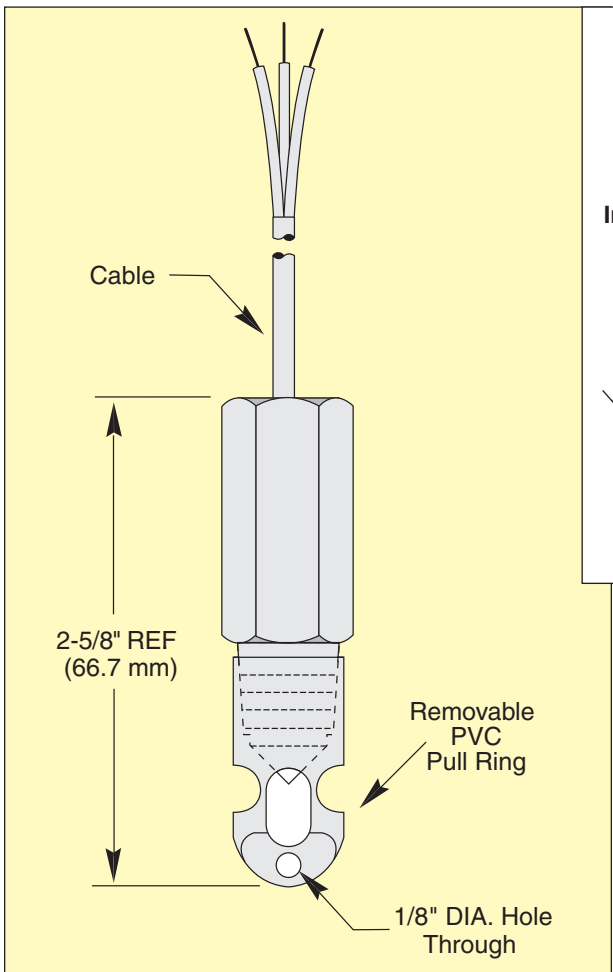

LV171, \$144, shown larger than actual size.

**Electrical Parameters**  
Entity Parameters for 10 to 28 Vdc Input

Terminal	V <sub>MAX</sub>	I <sub>MAX</sub>	C <sub>i</sub>	L <sub>i</sub>
Red/Black	38 V	150 mA	0.052 µf	0
White/Black	38 V	150 mA	0.052 µf	0

$V_{MAX} \geq V_{OC}$  (Barrier)  
 $I_{MAX} \geq I_{SC}$  (Barrier)  
 $C_i + C_{cable} \leq C$  (Barrier)  
 $L_i + L_{cable} \leq L$  (Barrier)

**Definitions:**

$V_{OC}$  = Maximum Open Circuit Voltage  
 $I_{SC}$  = Maximum Short Circuit Current  
 $C_i$  = Internal Capacitance  
 $L_i$  = Internal Inductance



**SPECIFICATIONS**

**Wetted Materials:**

Polysulfone, PVC, epoxy

**Operating Temperature:**

-18 to 80°C (0 to 176°F)

**Current Consumption:**

Approximately 17 mA

**Output:** TTL/CMOS compatible; may sink up to 40 mA

**Cable:** 3-conductor PVC jacketed [7.6 m (25') extended]

**Approvals:** UL for Class I, Group D Hazardous Locations

**Weight:** 340 g (0.75 lb)

**Max. Pressure:** 150 psig

**MOST POPULAR MODELS HIGHLIGHTED!**

To Order (Specify Model Number)		
Model No.	Price	Output Conditions
LV171	\$144	Wet probe = current sink
LV172	144	Dry probe = current sink

Comes with 7.6 m (25'), 3-conductor PVC jacketed cable and complete operator's manual.

**Ordering Example:** LV171, wet probe sensor, \$144.

**Typical Wiring Diagram**

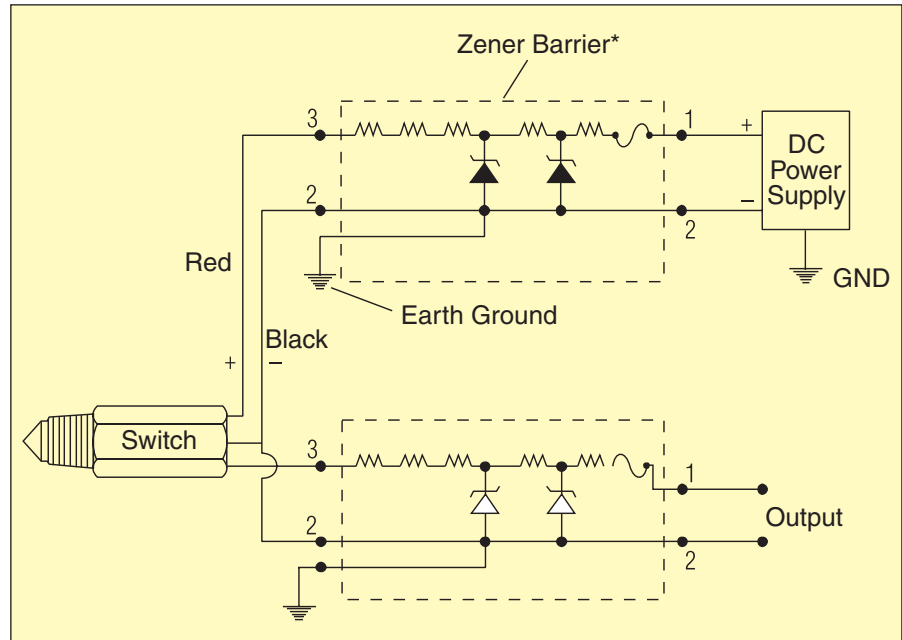

\*Source voltage not greater than 250 Vac. Zener barriers must be installed in accordance with barrier manufacturer's instructions.

# omega.co.uk<sup>®</sup>

Your One-Stop Source for Process Measurement and Control!

Freephone 0800 488 488 | International +44(0) 161 777 6622 | Fax +44(0) 161 777 6622 | Sales@omega.co.uk

[www.omega.co.uk](http://www.omega.co.uk)



#### UNITED STATES

[www.omega.com](http://www.omega.com)

1-800-TC-OMEGA  
Stamford, CT.

#### UNITED KINGDOM

[www.omega.co.uk](http://www.omega.co.uk)

Manchester, England  
0800-488-488  
+44-(0)161-777-6611

#### CANADA

[www.omega.ca](http://www.omega.ca)

Laval(Quebec)  
1-800-TC-OMEGA

#### FRANCE

[www.omega.fr](http://www.omega.fr)

0800-466-342

#### GERMANY

[www.omega.de](http://www.omega.de)

Deckenfronn, Germany  
0800-8266342

#### BENELUX

[www.omega.nl](http://www.omega.nl)

0800-099-33-44



## More than 100,000 Products Available!

### • Temperature

Calibrators, Connectors, General Test and Measurement Instruments, Handheld Instruments for Temperature Measurement, Ice Point References, Indicating Labels, Crayons, Cements and Lacquers, Infrared Temperature Measurement Instruments, Recorders, Relative Humidity Measurement Instruments, PT100 Probes, PT100 Elements, Temperature & Process Meters, Timers and Counters, Temperature and Process Controllers and Power Switching Devices, Thermistor Elements, Probes and Assemblies, Thermocouples, Thermowells and Head and Well Assemblies, Transmitters, Thermocouple Wire, RTD Probes

### • Flow and Level

Air Velocity Indicators, Doppler Flowmeters, Level Measurement, Magnetic Flowmeters, Mass Flowmeters, Pitot Tubes, Pumps, Rotameters, Turbine and Paddle Wheel Flowmeters, Ultrasonic Flowmeters, Valves, Variable Area Flowmeters, Vortex Shedding Flowmeters

### • pH and Conductivity

Conductivity Instrumentation, Dissolved Oxygen Instrumentation, Environmental Instrumentation, pH Electrodes and Instruments, Water and Soil Analysis Instrumentation

### • Data Acquisition

Communication Products and Converters, Data Acquisition and Analysis Software, Data Loggers Plug-in Cards, Signal Conditioners, USB, RS232, RS485, Ethernet and Parallel Port Data Acquisition Systems, Wireless Transmitters and Receivers

### • Pressure, Strain and Force

Displacement Transducers, Dynamic Measurement Force Sensors, Instrumentation for Pressure and Strain Measurements, Load Cells, Pressure Gauges, Pressure Reference Section, Pressure Switches, Pressure Transducers, Proximity Transducers, Regulators, Pressure Transmitters, Strain Gauges, Torque Transducers, Valves

### • Heaters

Band Heaters, Cartridge Heaters, Circulation Heaters, Comfort Heaters, Controllers, Meters and Switching Devices, Flexible Heaters, General Test and Measurement Instruments, Heater Hook-up Wire, Heating Cable Systems, Immersion Heaters, Process Air and Duct, Heaters, Radiant Heaters, Strip Heaters, Tubular Heaters