



ECONOMICAL DIFFERENTIAL PRESSURE SWITCH

7 to 250 psi
0.25 A SPDT Switch

PSW845 Series



PSW845-1 shown actual size.

The PSW845 is a rugged differential pressure switch, with excellent bypass characteristics. It is able to handle a variety of media to 6000 psig. The PSW845 can be mounted in any orientation, and is capable of withstanding light to moderate mechanical shock and vibratory loads.

SPECIFICATIONS

Switch: SPDT, rated 0.25 A @ 120 Vac/175 Vdc

Pressure Ratings:

Vacuum: to 6000 psig

Differential Pressure: to 2000 psid

Proof: 9000 psig

Wetted Parts: Steel spring, anodized aluminum piston, body and fitting, Buna seal, Loctite #271 sealing compound

Fitting: 1/4-18 NPT female

Electrical Connection: 300 mm (12") pigtail leads, 24 AWG

Ambient Temperature: -54 to 107°C (-65 to 225°F); setpoint change of up to 2% of sensor capacity may be anticipated when switch is used below -23°C or above 52°C

Cycling: Not to exceed 20 cycles/min

Dimensions:

102 L x 38.1 H x 31.8 mm D (4 x 1.5 x 1.25")

Weight: Approx 241 g (8.5 oz)

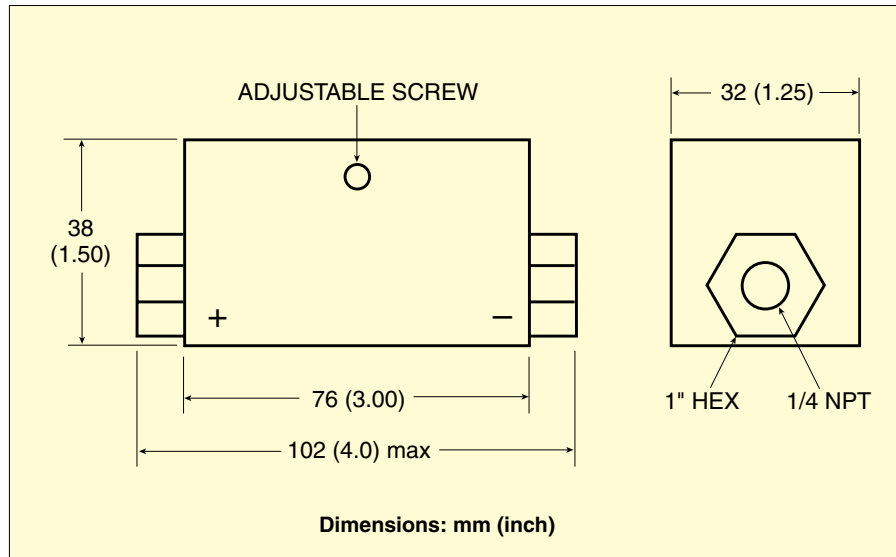

To Order Visit omega.com/psw845 for Pricing and Details

MODEL NO.	ADJUSTABLE RANGE (psid)		REPEATABILITY
	DECREASING	INCREASING	
PSW845-1	2 to 7	7 to 13	±2 psi
PSW845-2	5 to 16	13 to 25	±4 psi
PSW845-3	10 to 21	25 to 45	±8 psi
PSW845-4	20 to 80	35 to 160	±16 psi
PSW845-5	35 to 120	120 to 250	±32 psi

Comes complete with operator's manual.

Ordering Example: PSW845-3, differential pressure switch with 25 to 45 psi range.

omega.co.uk[®]

Your One-Stop Source for Process Measurement and Control!

Freephone 0800 488 488 | International +44(0) 161 777 6622 | Fax +44(0) 161 777 6622 | Sales@omega.co.uk

www.omega.co.uk



UNITED STATES

www.omega.com

1-800-TC-OMEGA
Stamford, CT.

UNITED KINGDOM

www.omega.co.uk

Manchester, England
0800-488-488
+44-(0)161-777-6611

CANADA

www.omega.ca

Laval(Quebec)
1-800-TC-OMEGA

FRANCE

www.omega.fr

0800-466-342

GERMANY

www.omega.de

Deckenfronn, Germany
0800-8266342

BENELUX

www.omega.nl

0800-099-33-44



More than 100,000 Products Available!

• Temperature

Calibrators, Connectors, General Test and Measurement Instruments, Handheld Instruments for Temperature Measurement, Ice Point References, Indicating Labels, Crayons, Cements and Lacquers, Infrared Temperature Measurement Instruments, Recorders, Relative Humidity Measurement Instruments, PT100 Probes, PT100 Elements, Temperature & Process Meters, Timers and Counters, Temperature and Process Controllers and Power Switching Devices, Thermistor Elements, Probes and Assemblies, Thermocouples, Thermowells and Head and Well Assemblies, Transmitters, Thermocouple Wire, RTD Probes

• Flow and Level

Air Velocity Indicators, Doppler Flowmeters, Level Measurement, Magnetic Flowmeters, Mass Flowmeters, Pitot Tubes, Pumps, Rotameters, Turbine and Paddle Wheel Flowmeters, Ultrasonic Flowmeters, Valves, Variable Area Flowmeters, Vortex Shedding Flowmeters

• pH and Conductivity

Conductivity Instrumentation, Dissolved Oxygen Instrumentation, Environmental Instrumentation, pH Electrodes and Instruments, Water and Soil Analysis Instrumentation

• Data Acquisition

Communication Products and Converters, Data Acquisition and Analysis Software, Data Loggers Plug-in Cards, Signal Conditioners, USB, RS232, RS485, Ethernet and Parallel Port Data Acquisition Systems, Wireless Transmitters and Receivers

• Pressure, Strain and Force

Displacement Transducers, Dynamic Measurement Force Sensors, Instrumentation for Pressure and Strain Measurements, Load Cells, Pressure Gauges, Pressure Reference Section, Pressure Switches, Pressure Transducers, Proximity Transducers, Regulators, Pressure Transmitters, Strain Gauges, Torque Transducers, Valves

• Heaters

Band Heaters, Cartridge Heaters, Circulation Heaters, Comfort Heaters, Controllers, Meters and Switching Devices, Flexible Heaters, General Test and Measurement Instruments, Heater Hook-up Wire, Heating Cable Systems, Immersion Heaters, Process Air and Duct, Heaters, Radiant Heaters, Strip Heaters, Tubular Heaters