

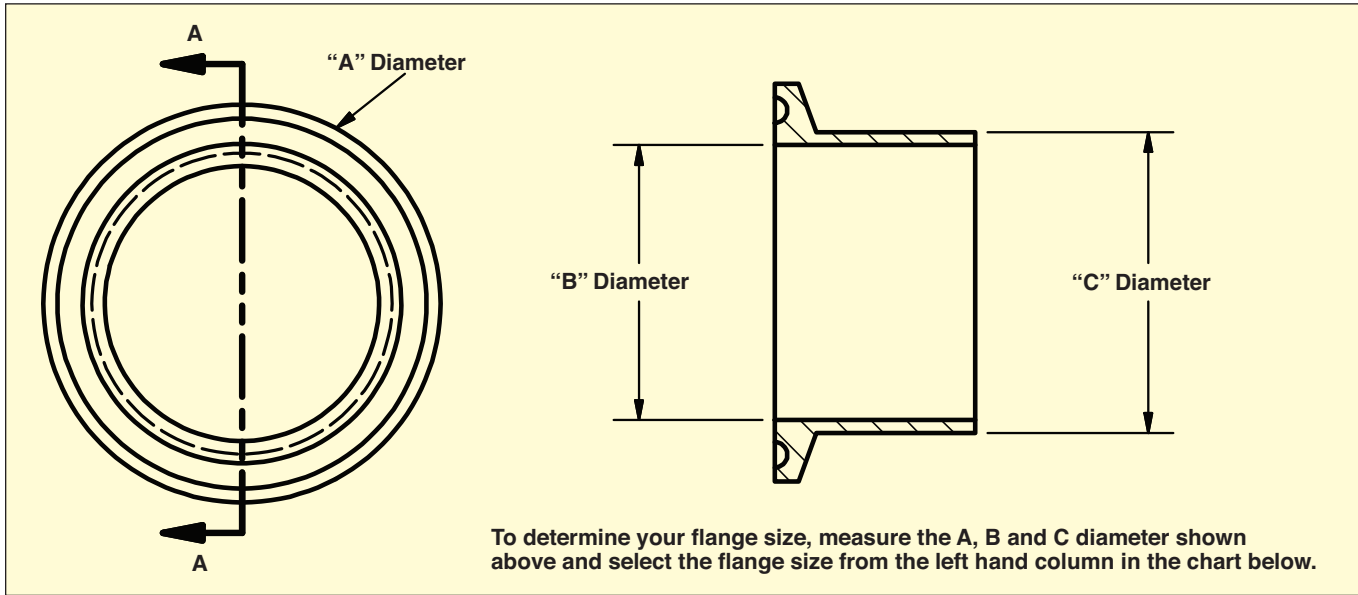

# TRI-GRIP™ PROCESS FLANGE SIZE GUIDE



TRI-GRIP® PROCESS MOUNTING FLANGE DIMENSIONS

FLANGE SIZE	A DIA	B DIA	C DIA
1/4"	0.98"	0.18"	0.25"
3/8"	0.98"	0.31"	0.375"
1/2"	0.98"	0.37"	0.50"
3/4"	0.98"	0.62"	0.75"
1"	1.98"	0.87"	1.00"
1 1/2"	1.98"	1.37"	1.50"
2"	2.52"	1.87"	2.00"
2 1/2"	3.05"	2.37"	2.50"
3"	3.58"	2.87"	3.00"
4"	4.68"	3.83"	4.00"
6"	6.57"	5.78"	6.00"



\*Tri-Grip™ (Tri-Clamp® compatible).